

CERTIFICATE OF OWNERSHIP AND DEDICATION

STATE OF TEXAS
COUNTY OF BRAZOS

I, JESSE C. WALL III, THE OWNER AND DEVELOPER OF THE LAND SHOWN ON THIS PLAT, BEING PART OF THE TRACT OF LAND AS CONVEYED TO ME IN VOLUME 17686, PAGE 225 OF THE OFFICIAL PUBLIC RECORDS OF BRAZOS COUNTY, TEXAS, AND WHOSE NAME IS SUBSCRIBED HERETO, HEREBY DEDICATE TO THE USE OF THE PUBLIC FOREVER ALL STREETS, ALLEYS, PARKS, WATERCOURSES, DRAINS, EASEMENTS AND PUBLIC PLACES HEREON SHOWN FOR THE PURPOSES IDENTIFIED.

JESSE C. WALL, III
OWNER

STATE OF TEXAS
COUNTY OF BRAZOS

BEFORE ME, THE UNDERSIGNED AUTHORITY, ON THIS DAY PERSONALLY APPEARED JESSE C. WALL III, KNOWN TO ME TO BE THE PERSON WHOSE NAME IS SUBSCRIBED TO THE FOREGOING INSTRUMENT, AND ACKNOWLEDGED TO ME THAT HE EXECUTED THE SAME FOR THE PURPOSES STATED.

GIVEN UNDER MY HAND AND SEAL OF OFFICE THIS \_\_\_ DAY OF \_\_\_, 20\_\_.

NOTARY PUBLIC, BRAZOS COUNTY, TEXAS

CERTIFICATE OF SURVEYOR

I, CHAD A. GULICK, A REGISTERED PUBLIC SURVEYOR NO. 6021 IN THE STATE OF TEXAS, HEREBY CERTIFY THAT THIS PLAT IS TRUE AND CORRECT AND WAS PREPARED FROM AN ACTUAL SURVEY OF THE PROPERTY AND THAT PROPERTY MARKERS AND MONUMENTS WERE PLACED UNDER MY SUPERVISION ON THE GROUND, AND THAT THE METES AND BOUNDS DESCRIBING SAID SUBDIVISION WILL DESCRIBE A CLOSED GEOMETRIC FORM.

CHAD A. GULICK
REGISTERED PROFESSIONAL LAND SURVEYOR
TEXAS REGISTRATION NO. 6021
TEXAS SURVEY FIRM NO. 10194550

CERTIFICATION BY THE COUNTY CLERK

I, COUNTY CLERK OF BRAZOS COUNTY, TEXAS, DO HEREBY CERTIFY THAT THIS PLAT TOGETHER WITH ITS CERTIFICATES OF AUTHENTICATION WAS FILED FOR RECORD IN MY OFFICE THE \_\_\_ DAY OF \_\_\_, 20\_\_ IN THE OFFICIAL RECORDS OF BRAZOS COUNTY IN VOLUME \_\_\_, PAGE \_\_\_.

BRAZOS COUNTY CLERK, BRAZOS COUNTY, TEXAS

APPROVAL OF THE PLANNING AND ZONING COMMISSION

I, CHAIR OF THE PLANNING AND ZONING COMMISSION OF THE CITY OF BRYAN, STATE OF TEXAS, HEREBY CERTIFY THAT THE ATTACHED PLAT WAS DULY FILED FOR APPROVAL WITH THE PLANNING AND ZONING COMMISSION OF THE CITY OF BRYAN ON THE \_\_\_ DAY OF \_\_\_, 20\_\_ BY SAID COMMISSION.

CHAIR, PLANNING & ZONING COMMISSION BRYAN, TEXAS

APPROVAL OF THE CITY PLANNER

I, DESIGNATED SECRETARY OF THE PLANNING AND ZONING COMMISSION OF THE CITY OF BRYAN, HEREBY CERTIFY THAT THIS PLAT IS IN COMPLIANCE WITH THE APPROPRIATE CODES AND ORDINANCES OF THE CITY OF BRYAN AND WAS APPROVED ON THE \_\_\_ DAY OF \_\_\_, 20\_\_.

CITY PLANNER, BRYAN, TEXAS

APPROVAL OF THE CITY ENGINEER

I, THE UNDERSIGNED, CITY ENGINEER OF THE CITY OF BRYAN, HEREBY CERTIFY THAT THIS PLAT IS IN COMPLIANCE WITH THE APPROPRIATE CODES AND ORDINANCES OF THE CITY OF BRYAN AND WAS APPROVED ON THE \_\_\_ DAY OF \_\_\_, 20\_\_.

CITY ENGINEER, BRYAN, TEXAS

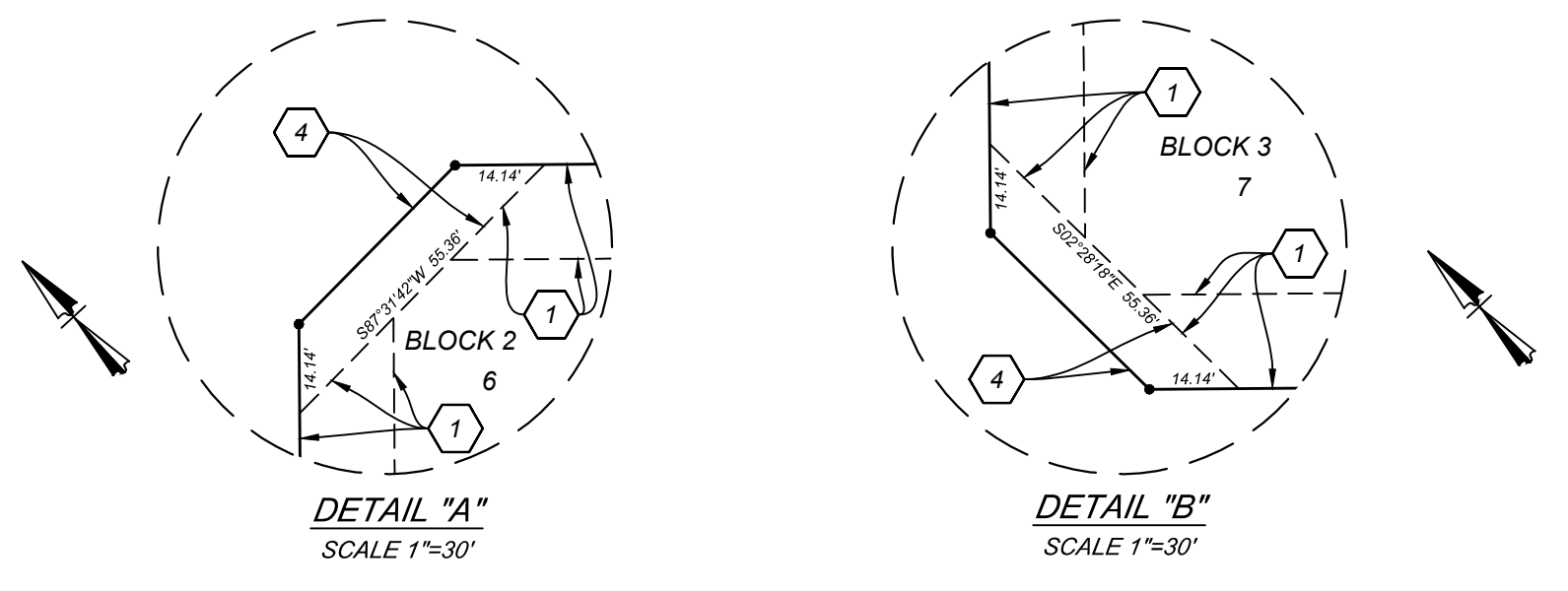

GENERAL NOTES

- 1. ALL BEARINGS AND COORDINATES ARE BASED ON THE TEXAS COORDINATE SYSTEM, CENTRAL ZONE (4203) NAD 83, EPOCH 2010.00.
2. ACCORDING TO THE NATIONAL FLOOD INSURANCE PROGRAM FLOOD INSURANCE RATE MAPS FOR BRAZOS COUNTY, TEXAS, MAP NUMBER 48041C025E, PANEL 025E, DATED MAY 16, 2012, ALL OF THIS PROPERTY IS LOCATED WITHIN UNSHADED ZONE "X", AREAS OF MINIMAL FLOOD HAZARD.
3. PER CITY OF BRYAN ORDINANCE NO. 2552, THIS PROPERTY HAS BEEN ANNEXED INTO THE CITY OF BRYAN ON APRIL 12, 2022.
4. THE BUILDING SETBACK REQUIREMENTS FOR THIS TRACT ARE ESTABLISHED BY THE CITY OF BRYAN ORDINANCES SEC. 62-161.
5. SANITARY SEWER: ALL SANITARY SEWER SERVICES SHALL BE IN ACCORDANCE WITH THE CITY OF BRYAN STANDARDS, ORDINANCES AND REGULATIONS; AND SHALL TERMINATE WITHIN RIGHT-OF-WAY 979-209-5030.
6. DOMESTIC WATER SERVICE: ALL DOMESTIC WATER SERVICES SHALL BE IN ACCORDANCE WITH THE CITY OF BRYAN STANDARDS, ORDINANCES AND REGULATIONS; AND SHALL TERMINATE WITHIN THE RIGHT-OF-WAY 979-209-5030.
7. ELECTRICAL SERVICE: BRYAN TEXAS UTILITIES (BTU) SHALL BE PROVIDING ELECTRICAL SERVICE TO THIS SUBDIVISION. 979-821-5784
8. ALL PUBLIC UTILITY EASEMENTS (PUE) SHOWN HEREON SHALL BE DEDICATED WITH THE PLATTING OF THIS SUBDIVISION.
9. WHERE ELECTRIC FACILITIES ARE INSTALLED, BTU HAS THE RIGHT TO INSTALL, OPERATE, RELOCATE, CONSTRUCT, RECONSTRUCT, ADD TO, MAINTAIN, INSPECT, PATROL, ENLARGE, REPAIR, REMOVE, AND REPLACE SAID FACILITIES UPON, OVER, UNDER, AND ACROSS THE PROPERTY INCLUDED IN THE PUE, AND THE RIGHT OF INGRESS AND EGRESS ON PROPERTY ADJACENT TO THE PUE TO PLACE AND MAINTAIN ELECTRIC FACILITIES.
10. DRIVEWAYS WILL BE LOCATED AND CONSTRUCTED IN ACCORDANCE WITH BCS GUIDELINES.
11. ALL DEVELOPMENT AND CONSTRUCTION SHALL BE IN ACCORDANCE WITH THE CITY OF BRYAN STANDARDS, ORDINANCES AND REGULATIONS.
12. THE CITY OF BRYAN IS RESPONSIBLE FOR THE MAINTENANCE OF FACILITIES WITHIN THE R.O.W. AND WITHIN PUBLIC UTILITY AND DRAINAGE EASEMENTS.
13. A HOMEOWNER'S ASSOCIATION (HOA) SHALL BE ESTABLISHED WITH DIRECT RESPONSIBILITY TO, AND CONTROLLED BY, THE PROPERTY OWNERS INVOLVED TO PROVIDE FOR OPERATION, REPAIR AND MAINTENANCE OF ALL COMMON AREAS, PRIVATE DRAINAGE EASEMENTS, AND PRIVATE STORMWATER DETENTION FACILITIES WHICH ARE PART OF THIS SUBDIVISION. THE CITY OF BRYAN SHALL NOT BE RESPONSIBLE FOR ANY OPERATION, REPAIR AND MAINTENANCE OF THESE AREAS EXCEPT FOR THE OPERATION, REPAIR AND MAINTENANCE OF THE PUBLIC INFRASTRUCTURE.
14. THE PROPOSED LAND USE WITHIN THIS FINAL PLAT IS FOR SINGLE-FAMILY RESIDENTIAL DEVELOPMENT. THE FINAL PLAT IS WITHIN "RD-S" ZONING DISTRICT AND IS SUBJECT TO THE RESTRICTIONS CONTAINED WITHIN THE ZONING ORDINANCE.
15. NO STRUCTURES, WALLS OR OTHER OBSTRUCTIONS OF ANY KIND SHALL BE PLACED WITHIN THE LIMITS OF DRAINAGE EASEMENTS.
16. COMMON AREA "A" DESIGNATED AS A PRIVATE DRAINAGE AND PUBLIC SEWER EASEMENT.
17. COMMON AREA "B" DESIGNATED AS A PUBLIC SEWER EASEMENT.
18. COMMON AREA "C" & COMMON AREA "D" DESIGNATED AS PRIVATE DRAINAGE EASEMENTS.

LEGEND

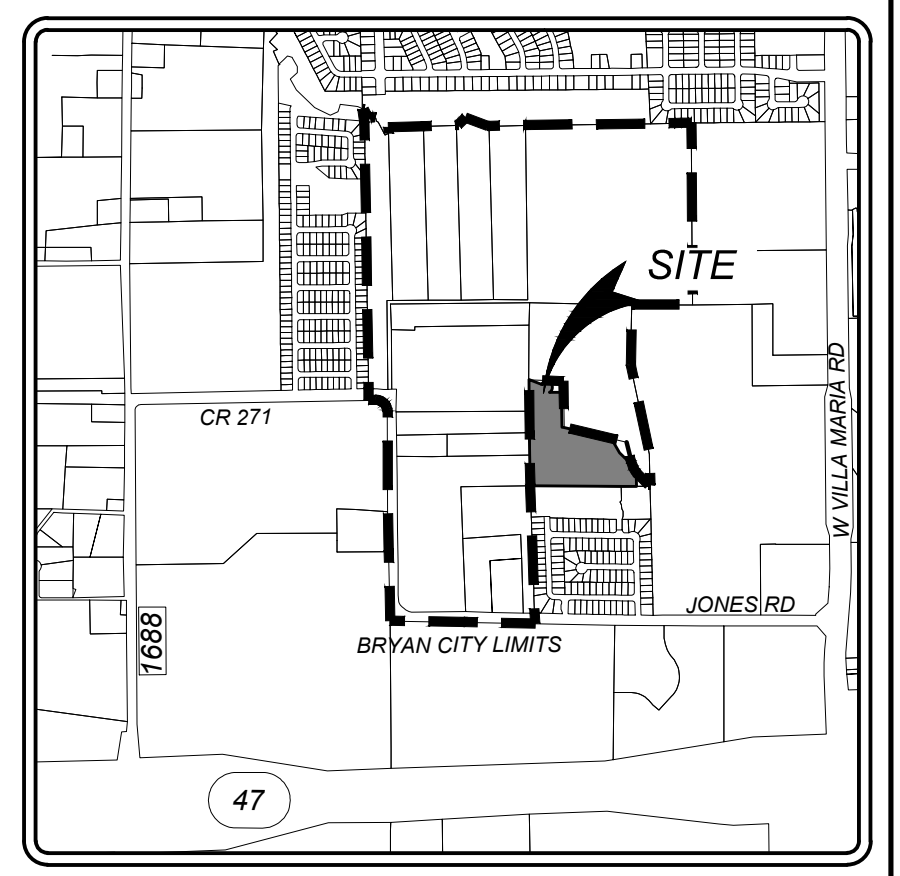
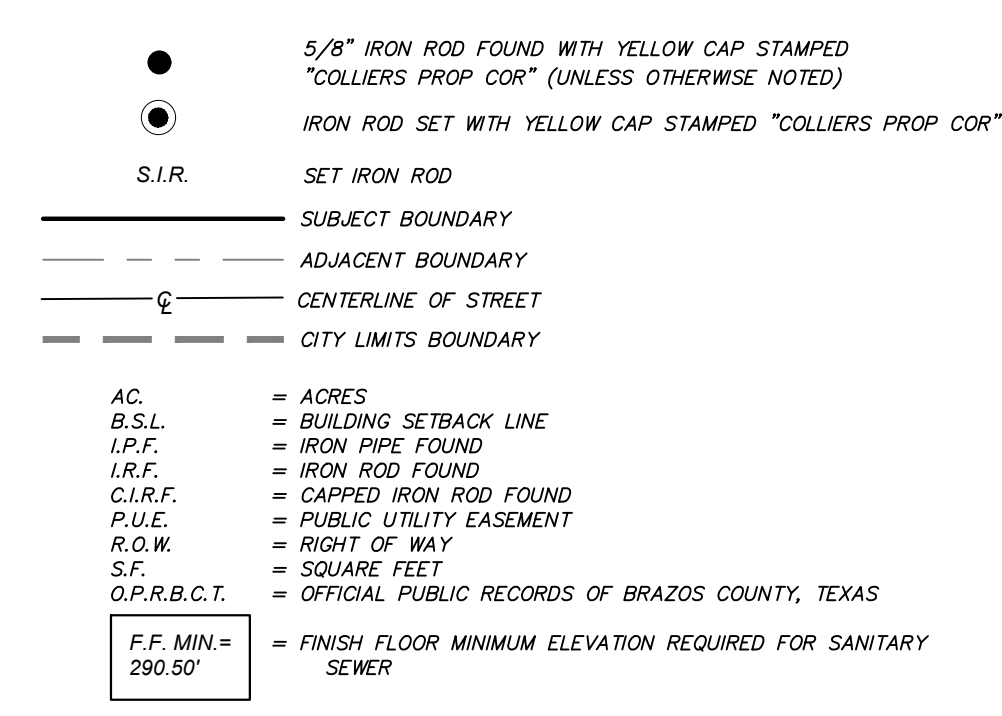

LEGAL DESCRIPTION OF SUBDIVISION:

BEING A 11.24-ACRE TRACT CONTAINED WITHIN THE T.J. WOOTON SURVEY, ABSTRACT NO. 59, BRAZOS COUNTY, TEXAS, AND BEING PART OF THAT CERTAIN CALLED 45.5618 ACRE TRACT AS CONVEYED TO JESSE C. WALL III IN A GENERAL WARRANTY DEED RECORDED IN VOLUME 17686, PAGE 225, OFFICIAL PUBLIC RECORDS OF BRAZOS COUNTY, TEXAS (O.P.R.B.C.T.), SAID 11.24-ACRE TRACT BEING MORE PARTICULARLY DESCRIBED BELOW:

BEGINNING AT A 1/2-INCH IRON ROD FOUND FOR THE WESTERNMOST CORNER OF SAID 45.5618 ACRE TRACT, BEING AT THE NORTHERNMOST CORNER OF THAT CERTAIN CALLED 19.977 ACRE TRACT AS CONVEYED TO WALL DEVELOPMENT, LLC AS "TRACT 1" IN A SPECIAL WARRANTY DEED RECORDED IN VOLUME 16684, PAGE 155, O.P.R.B.C.T., THE EASTERNMOST SOUTHEAST CORNER OF THAT CERTAIN CALLED 20.803 ACRE TRACT AS CONVEYED TO REALSPIN INVESTMENT TRUST IN A WARRANTY DEED WITH VENDOR'S LIEN RECORDED IN VOLUME 12330, PAGE 14, O.P.R.B.C.T., AND THE NORTHEAST CORNER OF LOT 1, BLOCK 1 OF JONES ROAD BUSINESS PARK AS RECORDED IN VOLUME 14082, PAGE 208, O.P.R.B.C.T.;

THENCE N 41° 49' 24" E, A DISTANCE OF 263.47 FEET, ALONG THE COMMON LINE OF SAID 45.5618 ACRE TRACT AND SAID 20.803 ACRE TRACT, TO A 1/2-INCH IRON ROD FOUND WITH CAP STAMPED "K. MCCLURE RPLS 5650" AT THE EASTERNMOST CORNER OF SAID 20.803 ACRE TRACT AND THE SOUTHERNMOST CORNER OF THAT CERTAIN CALLED 4.97 ACRE TRACT AS CONVEYED TO ROBERT JACKSON AND LAURELLE E. JACKSON IN A GENERAL WARRANTY DEED RECORDED IN VOLUME 12247, PAGE 85, O.P.R.B.C.T.;

THENCE N 42° 47' 44" E, A DISTANCE OF 188.94 FEET, ALONG THE COMMON LINE OF SAID 45.5618 ACRE TRACT AND SAID 4.97 ACRE TRACT, TO A 1/2-INCH IRON ROD FOUND AT THE EASTERNMOST CORNER OF SAID 4.97 ACRE TRACT AND THE SOUTHERNMOST CORNER OF THAT CERTAIN CALLED 5.28 ACRE TRACT AS CONVEYED TO ROBERT C. JACKSON AND ELAIN L. JACKSON IN A WARRANTY DEED WITH VENDOR'S LIEN RECORDED IN VOLUME 879, PAGE 43, O.P.R.B.C.T.;

THENCE N 42° 32' 54" E, A DISTANCE OF 456.52 FEET, ALONG THE NORTHWEST LINE OF SAID 45.5618 ACRE TRACT, TO A 5/8-INCH IRON ROD WITH CAP STAMPED "COLLIERS PROP COR" FOUND ON THE COMMON LINE OF SAID 45.5618 ACRE TRACT AND THAT CERTAIN CALLED 19.76 ACRE TRACT AS CONVEYED TO GRABER WYATT FAMILY TRUST IN A SPECIAL WARRANTY DEED RECORDED IN VOLUME 14415, PAGE 126, O.P.R.B.C.T.;

THENCE OVER AND ACROSS SAID 45.5618 ACRE TRACT, THE FOLLOWING BEARINGS AND DISTANCES: -S33° 39' 43" E, A DISTANCE OF 122.18 FEET, TO A SET 5/8-INCH IRON ROD WITH CAP STAMPED "COLLIERS PROP COR" FOR A POINT OF NON-TANGENT CURVATURE TO THE RIGHT;

-WITH A CURVE TO RIGHT HAVING AN ARC LENGTH OF 143.78 FEET, A RADIUS OF 50.00 FEET, A DELTA ANGLE OF 164° 45' 45" AND A CHORD BEARS, S01° 01' 54" E, A DISTANCE OF 99.12 TO A SET 5/8-INCH IRON ROD WITH CAP STAMPED "COLLIERS PROP COR";

-S47° 28' 18" E, A DISTANCE OF 89.10 FEET, TO A SET 5/8-INCH IRON ROD WITH CAP STAMPED "COLLIERS PROP COR"; -S42° 09' 26" W, A DISTANCE OF 310.01 FEET, TO A SET 5/8-INCH IRON ROD WITH CAP STAMPED "COLLIERS PROP COR"; -S43° 27' 11" E, A DISTANCE OF 20.06 FEET, TO A SET 5/8-INCH IRON ROD WITH CAP STAMPED "COLLIERS PROP COR"; -S33° 44' 39" E, A DISTANCE OF 413.35 TO A SET 5/8-INCH IRON ROD WITH CAP STAMPED "COLLIERS PROP COR"; -S12° 49' 37" W, A DISTANCE OF 143.06 FEET, TO A SET 5/8-INCH IRON ROD WITH CAP STAMPED "COLLIERS PROP COR"; -S02° 04' 33" E, A DISTANCE OF 142.16 FEET, TO A SET 5/8-INCH IRON ROD WITH CAP STAMPED "COLLIERS PROP COR"; -S17° 47' 52" W, A DISTANCE OF 97.40 FEET, TO A SET 5/8-INCH IRON ROD WITH CAP STAMPED "COLLIERS PROP COR"; -S42° 08' 02" W, A DISTANCE OF 100.00 FEET, TO A SET 5/8-INCH IRON ROD WITH CAP STAMPED "COLLIERS PROP COR"; AND BEING ON THE SOUTH LINE OF SAID 45.5618 ACRE TRACT AND THE NORTHERLY LINE OF A PRIVATE DRAINAGE EASEMENT LOT AS SHOWN ON THE PLAT OF FOXWOOD CROSSING PHASE 1, AN ADDITION TO THE CITY OF BRYAN, BRAZOS COUNTY, TEXAS AS RECORDED IN VOLUME 17420, PAGE 53, O.P.R.B.C.T.;

THENCE N 47° 51' 58" W, A DISTANCE OF 120.00 FEET, ALONG THE COMMON LINE OF SAID 45.5618 ACRE TRACT AND SAID PRIVATE DRAINAGE EASEMENT LOT RECORDED IN VOLUME 17420, PAGE 53, O.P.R.B.C.T.;

THENCE N 46° 17' 08" W, A DISTANCE OF 789.73 FEET, ALONG THE COMMON LINE OF SAID 45.5618 ACRE TRACT AND SAID 19.977 ACRE TRACT, TO THE POINT OF BEGINNING, AND CONTAINING 11.24 ACRES OF LAND.

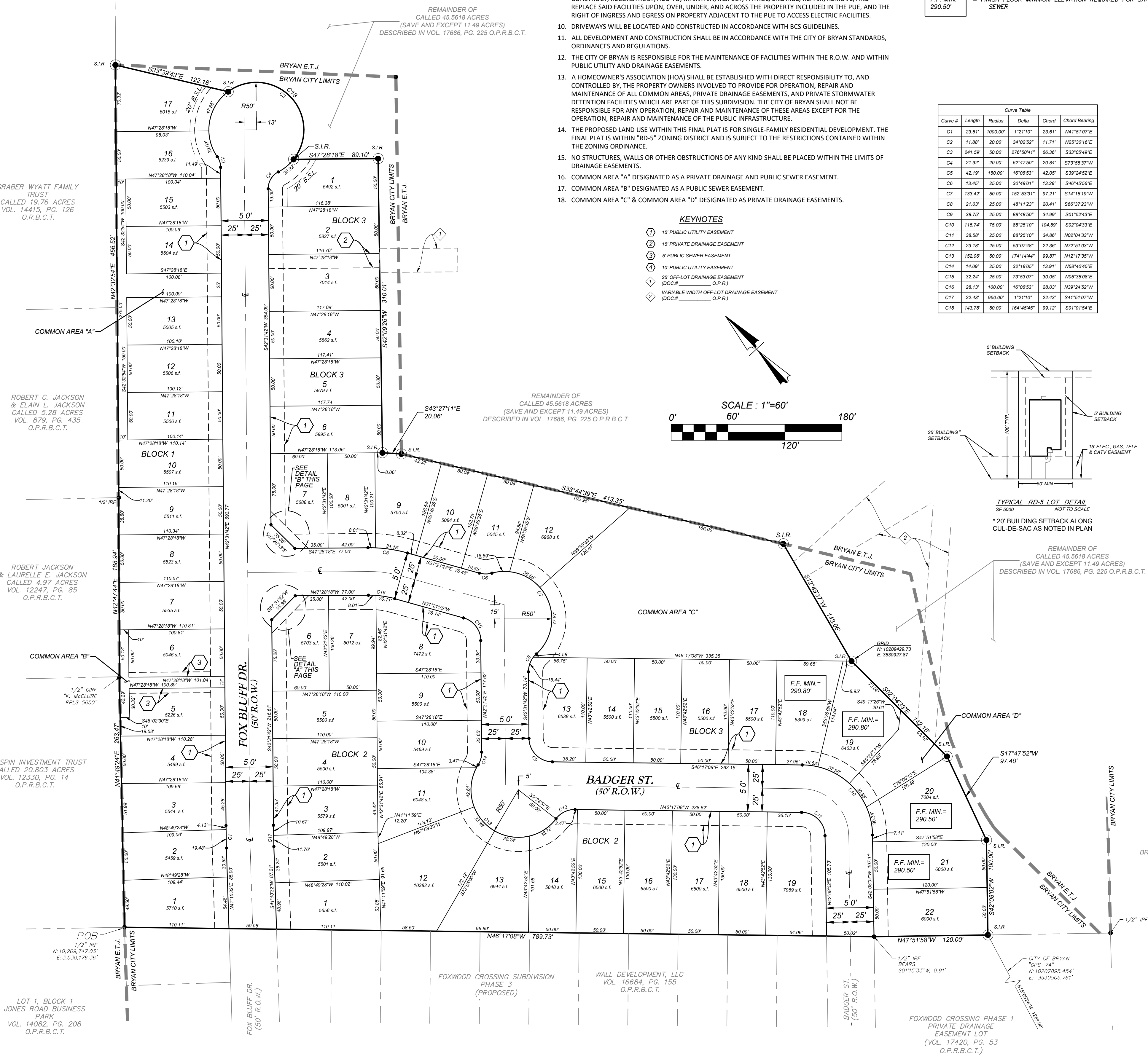

KEYNOTES

- 1. 15' PUBLIC UTILITY EASEMENT
2. 15' PRIVATE DRAINAGE EASEMENT
3. 5' PUBLIC SEWER EASEMENT
4. 10' PUBLIC UTILITY EASEMENT
5. 25' OFF-LOT DRAINAGE EASEMENT (DOE-C)
6. VARIABLE WIDTH OFF-LOT DRAINAGE EASEMENT (DOE-C) (O.P.R.)

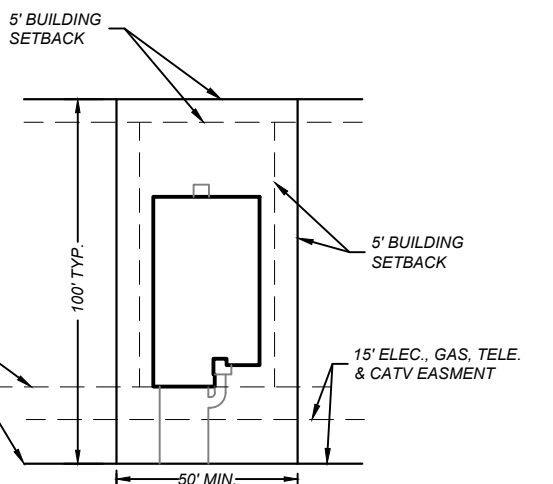
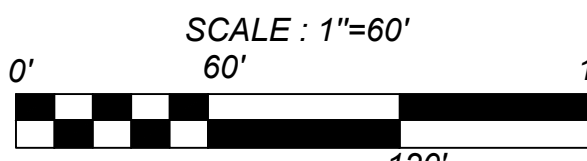

OWNER/DEVELOPER: JESSE C. WALL III, 8702 ADAMS LANE, TEMPLE, TX 76702, 254-721-6179
ENGINEER: KFW ENGINEERS & SURVEYING, 162 W Mill St, New Braunfels, TX 78130, Phone #: (830) 220-0042, Fax #: (210) 979-8441, TBPE Firm #: 9513, TBPLS Firm #: 10122300
SURVEYOR: COLLIERS ENGINEERING & DESIGN, 4500 RATLIFF LANE #113, ADDISON, TEXAS 75001, 214-613-1204



58 Lots
Block 1, Lots 1-17
Block 2, Lots 1-19
Block 3, Lots 1-22

FINAL PLAT ESTABLISHING TIMBER OAKS SUBDIVISION

BEING A 11.24-ACRE TRACT CONTAINED WITHIN THE T.J. WOOTON SURVEY, ABSTRACT NO. 59, BRAZOS COUNTY, TEXAS, AND BEING PART OF THAT CERTAIN CALLED 45.5618 ACRE TRACT AS CONVEYED TO JESSE C. WALL III IN A GENERAL WARRANTY DEED RECORDED IN VOLUME 17686, PAGE 225, OFFICIAL PUBLIC RECORDS OF BRAZOS COUNTY, TEXAS (O.P.R.B.C.T.).